



POWERHOLD 6000 RESILIENT FLOOR ADHESIVE

POWERHOLD

DESCRIPTION:

Powerhold 6000 Resilient Floor Adhesive is a latex based adhesive that has been specially formulated for the installation of mineral fibrous felt-backed floor covering. Powerhold 6000 dries light in color and will not create any adhesive induced (below the surface) discoloration.

While the adhesive is designed to meet the challenges of poorly ventilated areas, sufficient air exchanges are still required to ensure proper curing of any latex-based adhesive.

Powerhold 6000 Adhesive is LEED compliant and is also compliant with South Coast Air Quality Management District Rule 1168.

E.Q. 4.1: Low-Emitting Materials: Adhesives & Sealants

E.Q. 4.3: Low-Emitting Materials: Carpet Systems

M.R. 5.1: Regional Materials: 10% Extracted, Processed & Manufactured Regionally

M.R. 5.2: Regional Materials: 20% Extracted, Processed & Manufactured Regionally

100% of all Raw Materials used to manufacture this adhesive are Extracted, Processed and Manufactured Regionally.

***LEED points are based on all materials used on a project.**

SUB-FLOOR PREPARATION:

Follow all manufacturer's recommendations and industry standards regarding sub-floor preparation. Moisture tests are required on all concrete sub-floors regardless of grade level if the concrete is freshly poured or is classified as an older slab. Moisture testing should be performed by ASTM F1869 Calcium Chloride Tests with moisture levels not to exceed three (3) pounds per twenty-four (24) hours per one thousand (1000) square feet, or ASTM F2170 In Situ Relative Humidity Test with readings not to exceed seventy-five (75) percent. Additional information with regard to these tests and results can be obtained through Powerhold's Technical Service Department.

DIRECTIONS:

1. Sub-floor must be clean, dry, smooth and free of any contamination, which may interfere with the adhesive bond. Seal all chalky, very porous floors.
2. Follow floor covering manufacturer's recommendations regarding layout, cutting, seaming and maintenance.
3. Place floor covering into wet adhesive and roll in both directions with a minimum 75 lb. roller.
4. Refer to floor covering manufacturer's recommendations regarding proper

seaming (cutting), seam sealing and maintenance procedures.

5. Lift floor covering periodically to check adhesive transfer to the backing. A 100% adhesive transfer is required to promote maximum adhesion.

RECOMMENDED SUBSTRATES:

- Concrete
- Portland Based Underlayments
- Properly Prepared Gypsum
- APA Approved Plywood
- Terrazzo
- Fiber Cement Underlayment
- Radiant Heated Sub-floors
- Properly Prepared VCT (Single Layer)
- Properly Prepared Sheet Vinyl (Single Layer, fully adhered)

RESTRICTIONS:

1. Do not use to install any vinyl or PVC flooring.
2. For Interior installations only.
3. Do not install over adhesive residue including cutback.
4. Do not install when MVER is over 3 lbs. per 1,000 sf per 24 hours, per ASTM F1869.
5. Do not install when relative humidity is over 75%, per ASTM F2170.
6. Do not install when ambient temperature is not between 60°F & 95°F.
7. Do not install when ambient relative humidity is above 65%.
8. It is the sole responsibility of the installer to determine the suitability and compatibility of the adhesive for the user's intended use.

CLEAN-UP:

Fresh adhesive can be removed immediately with a damp cloth. If adhesive has dried, use Powerhold 050 Cleaner or Mineral Spirits. Do not allow solvent to penetrate seams. Solvent will dissolve adhesive bond.

CAUTION: Mineral Spirits are flammable. Read and follow all precautions on container label.

PACKAGING:

- One 4 Gallon Pail

WARRANTY:

Powerhold offers a limited warranty for this product when used in accordance with printed specifications. A copy of the limited warranty can be obtained by calling 844 638-4583(**GLUE**) or visiting www.powerhold.net.



POWERHOLD 6000 RESILIENT FLOOR ADHESIVE

POWERHOLD

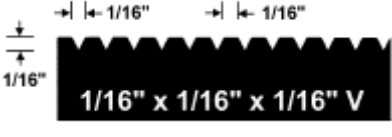
FLOORING	TROWEL	ESTIMATED SPREAD RATE
Felt-Backed Sheet Flooring (Porous)		20 sq/yards per gallon
Felt-Backed Sheet Flooring (Non-Porous)		23 sq/yards per gallon